



Technical Description

Digital battery monitor and alarm displays battery voltage and up to two ammeters.

The InPower DSP2-DCS35-200-1 is a multifunction instrument that includes a DC voltmeter and two ammeters. Its backlit liquid crystal display (LCD) is easy to read in low ambient light conditions as well as in direct sunlight. A built-in low battery voltage alarm provides a flashing battery voltage display and sets the Alarm output (+24 volts @ 0.5 amps) when the battery voltage drops below 24.0 volts or increases to above 35 volts. It also includes a Silence Alarm control input. If the Alarm output is set and a ground is applied to the Silence Alarm input, the Alarm output will be turned off, but the voltage display will continue to flash until the battery voltage is within normal limits.

The dual ammeter function utilizes InPower Model DCS-35-200-1 Hall-effect current sensors to measure DC current in the range of -200 to +200 amps. The system is pre-calibrated, so there is no need for adjustments at installation. Moreover, the system provides an automatic configuration that detects if one, two, or no current sensors are connected, and automatically formats the digital display accordingly. For example, if no current sensors are detected, the display will only show the battery voltage information.

The battery monitor mounts easily on a flat panel with cutout. No fasteners are visible from the front. It contains 0.25 inch Faston male blade terminals on the rear of the unit for the interface connections.

Key Features

- Battery DC Voltage Display
- Dual DC Ammeter Display
- Backlit LCD Digital Display
- Low Battery Voltage Alarm
- Auto-Configures Number of Ammeters
- Uses Standard InPower DC Current Sensors
- No Calibration Required
- Customized functions available

System Diagram

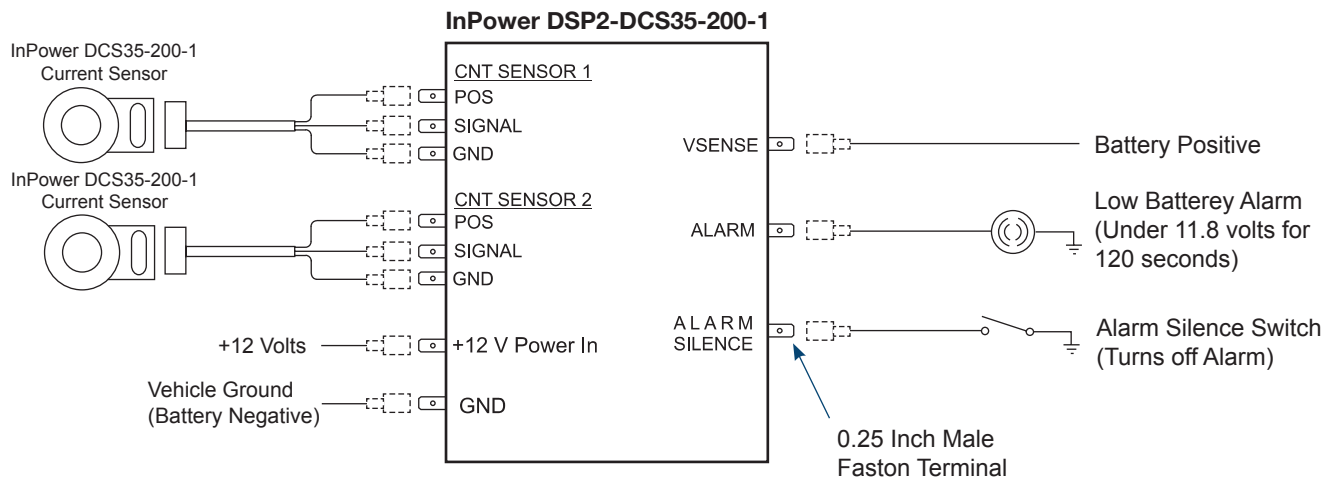

Specifications

Operating Voltage Range:	+8 to +30 Vdc
Operating Current Range:	0.065 amps for the display, plus the current used by the Alarm control output (0-0.5 amps)
Voltmeter Measurement Range:	0 Vdc to 50 Vdc
Ammeter Range:	-200 to +200 amps
Ammeter Sensor:	InPower Model DC35-200-2 (One or two Required)
Terminals:	Male 0.25 inch Faston (blade)
Display Type:	Backlit LCD
Display Character Height:	0.20 Inch (20 mm)
Alarm System:	
Low Voltage Indication:	The voltage display will flash when the Battery Sense is <24.0 Vdc or >30.0 Volts
Alarm Control Output:	+24 volts @ 0.5 amps
Silence Alarm Control Input:	Apply ground to turn off Alarm output.
Operating Temperature:	-20° C to +80° C

Mechanical Drawing

