

# ETM51

# Ford Electronic Throttle

**Supported Through the 2019 Model Year Only!**



**Fast Idle Speed Control for E and F-Series Ford Trucks, Vans and Cut-Away Chassis with SEIC circuits.**

### Vehicle Compatibility

This electronic throttle is compatible with only certain Ford vehicle configurations. To determine the electronic throttle that matches your vehicle model year, chassis, engine and transmission refer to the Throttle Selector menu of InPower's web site, [www.InPowerLLC.com](http://www.InPowerLLC.com).

### Technical Description

The ETM51 throttle module has four selectable modes of fast engine idle operation, including three adjustable preset fixed speeds and one variable speed control via an external potentiometer. Select the mode by applying +12 volts to the RPM1, RPM2 or RPM3 terminal. The three presets can be individually adjusted by calibration potentiometers accessible on the top of the module. Ten LEDs display the selected operating mode, system status, and error conditions. The ETM51 controller module is compact, measuring only 2 x 4 inches. Wiring terminations utilize 0.25 inch Faston blade terminals. Its circuitry is encapsulated for maximum environmental protection.

Installation is simplified with a wiring harness that plugs into the vehicle's engine data bus, eliminating the need to wire into chassis sensors or the accelerator pedal module. The ETM51 module mounts under the dash and is supplied with a three foot cable that plugs into the vehicle's OBDII Data Link Connector. Customer provided wiring is required to select the fast idle mode and to connect to the Ford SEIC harness (three blunt-cut wires).

### Applications

- Emergency Vehicles
- Work Trucks
- Transit and Shuttle Buses
- Pumper Trucks
- Service and Rescue Vehicles
- Hydraulic Systems
- Air Compressors
- Power Inverter Systems
- Warning Light Systems

### Key Features

- Three user-adjustable speed presets with priority control.
- Variable speed input for remote control of fast idle speed.
- Works in conjunction with Ford's built-in Stationary Elevated Idle Control (SEIC).
- Engine Control Module programming for speed presets not required.
- LED status and troubleshooting indicators.
- Consistent speed ramp rate control between speed presets.
- Works on model years 2005+ with built-in SEIC

### System Diagram

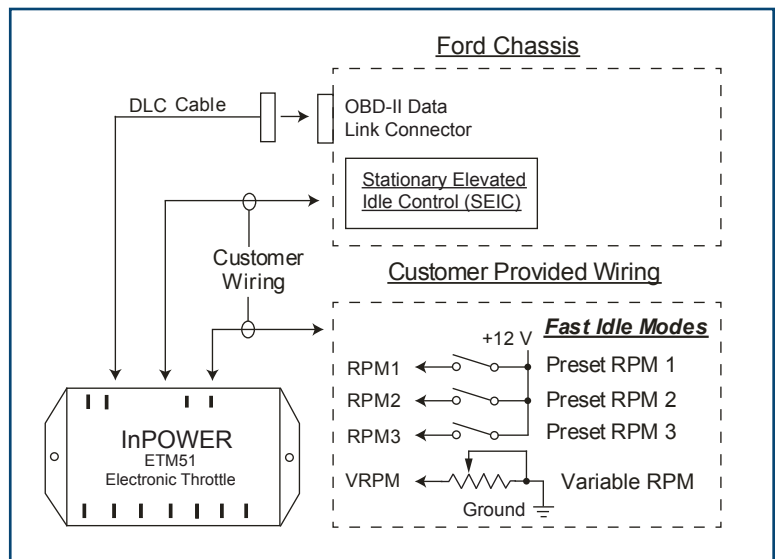

## Specifications

### Modes of Operation

#### A. Preset RPM Modes

Function:	Increases idle to a preset RPM
Number of presets:	Three
Input identification:	RPM1, RPM2 & RPM3 (RPM1 has highest priority, then RPM2, and RPM3 the lowest priority).
Activation:	Apply +12 V to input to select mode
Range of calibration:	
Diesel Engine:	1200 to 2400 RPM
Gas Engines:	900 to 2340 RPM
Calibration method:	Internal potentiometers (3)

#### B. Variable RPM Mode

Function:	Varies RPM as a function of external resistance change
Input identification:	VRPM
Adjustment:	10k Ohm potentiometer between input terminal and ground
RPM range:	Diesel Engines: 1200 to 2400 RPM Gas Engines: 900 to 2340 RPM

#### Power Requirements

Input Voltage:	8 to 16 volts DC (from Ignition Switch)
Input Current:	30 milliamps

#### NOTES

1. Refer to Ford Body Builders Manual for application restrictions that may apply.
2. Certain chassis are not supported as they do not have the Ford SEIC feature.
3. For Charge Protect function refer to the SEIC documentation.
4. Refer to InPower Owners Manual OM-54 for installation and operating instructions.

## Mechanical

