

# OWNERS MANUAL

## ITM137 Platform Lift Interlock System for 2009+ Chevy & GMC Van and Cutaway Chassis

### Contents

1. Introduction .....	1
2. Product Description .....	2
3. System Operation .....	2
4. Interlock System Diagram.....	3
5. System Circuit Diagrams .....	4
6. Installation Procedures .....	6
7. Wiring Instructions .....	7
8. System Troubleshooting .....	8
9. Mechanical Drawings.....	9
10. Reference information .....	9

### 1. Introduction

This system is intended for installation in 2009+ Chevy and GMC passenger van and cutaway chassis with FMVSS compliant, public-use platform lifts manufactured by The Braun Corporation, Ricon Corporation or Maxon Mobility. If another type of lift is to be used, contact the lift manufacturer to determine compatibility.

The system is designed to meet the requirements of FMVSS 403/404 and therefore must be installed in accordance with the lift manufacturer's instructions. The installer must be trained and skilled in installing FMVSS compliant lift systems. The installation must also comply with SAE (Society of Automotive Engineers) and Chevy/GMC electrical wiring procedures.

## 2. Product Description

InPower's Model ITM137 platform lift interlock systems consist of a control module with integral driver's status display and a chassis wiring harness (See Interlock System Diagram on Page 3). The interlock's control/display module is intended to mount on the dash with its wiring harness routed through the dash. The harness contains two Tee-cables that connect to the shift lock solenoid and parking brake switch. The harness also contains a set of blunt-cut wires for connection to the three door switches, +12 volt power, lift door switch and Lift Enable output to the platform lift system.

The ITM137 interlock system provides inputs from the platform lift door switch and three other door switches (Door 1 Switch, Door 2 Switch and Door 3 Switch). Anytime Door Switches 1, 2 or 3 are actuated (door not fully closed) the DOOR AJAR display indicator will flash. Anytime the Lift Door Switch is activated (door not fully closed) the DOOR AJAR display indicator will flash and the shift lock will be set. And if in PARK with the parking brake set, the Lift Enable will be set allowing the platform lift to be operated.

## 3. System Operation

The interlock system is powered only when the Ignition Switch is on. The following is the interlock system sequence of operation:

- Step 1 - Turn the Ignition switch on and start the engine.
- Step 2 - Press the service brake and place shifter in Park.
- Step 3 - Set the parking brake.
  - The Shift Lock will activate
- Step 4 - Open lift door.
  - The display Door Ajar indicator will flash
  - The Lift Enable will activate allowing operation of platform lift.
- Step 5 - The platform lift may now be operated (Refer to the platform lift operating instructions).
  - During the Lift Enable sequence, if the parking brake is released the Lift Enable will be deactivated, preventing lift operation.
- Step 6 - When the lift cycle is completed return the lift to its fully stowed position.
- Step 7 - Close the lift door.
- Step 8 - Release parking brake. When released, the interlock will release the shift lock.
- Step 9 - The cycle is now complete and the vehicle can be taken out of Park and driven.

### Notes:

1. Anytime Doors #1, #2 or #3 are opened (or ajar) the Door Ajar indicator will flash but the shifter will not lock unless the parking brake is also set.

## 4. Interlock System Diagram

### Platform Lift Interlock System

#### Interlock Control Module

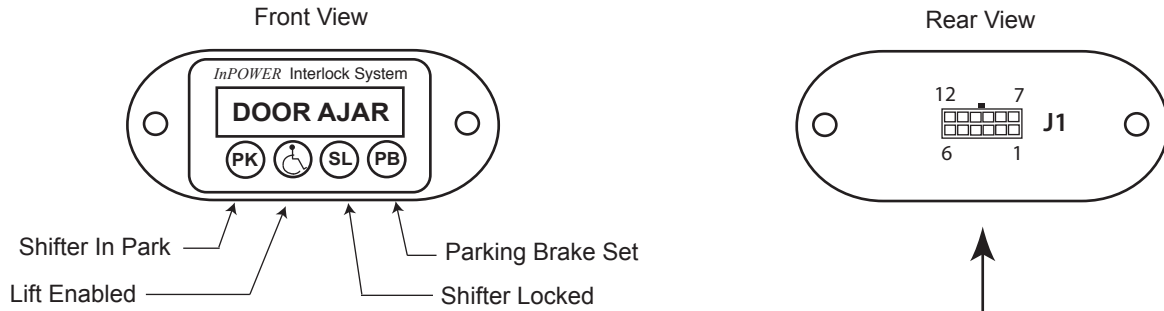

#### Chassis Wiring Harness 7201.049A

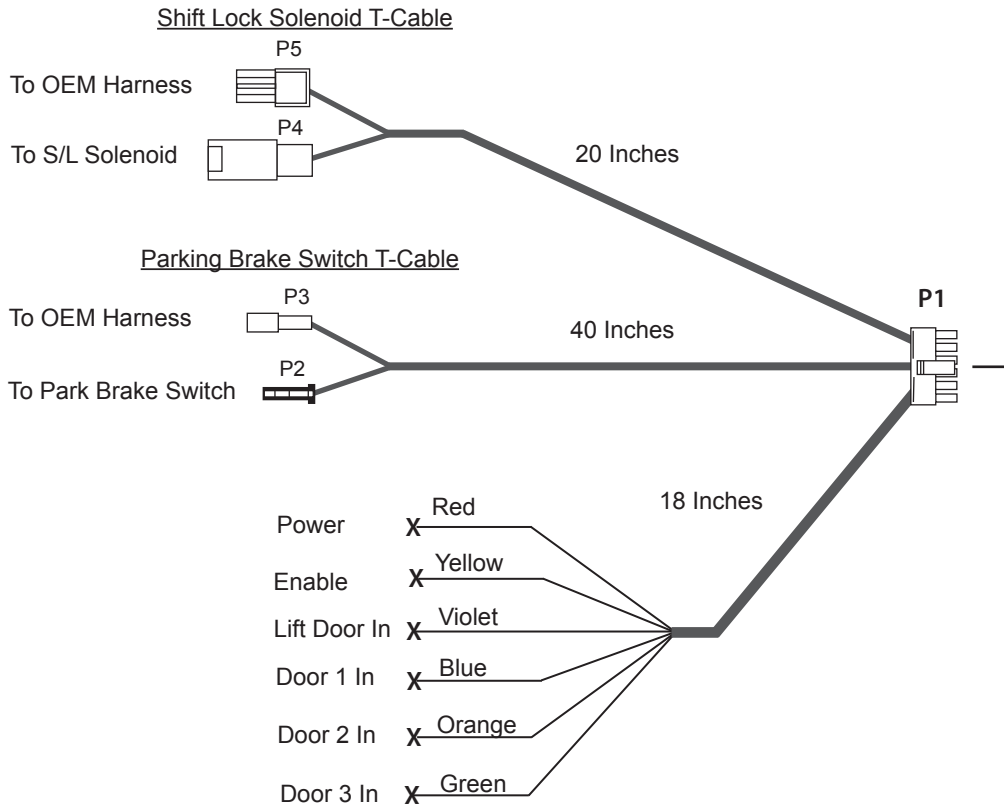

## 5. System Circuit Diagrams

The following pages show the individual circuits that need to be wired. Refer to *Section 7. Wiring Instructions* for details on how to wire these circuits.

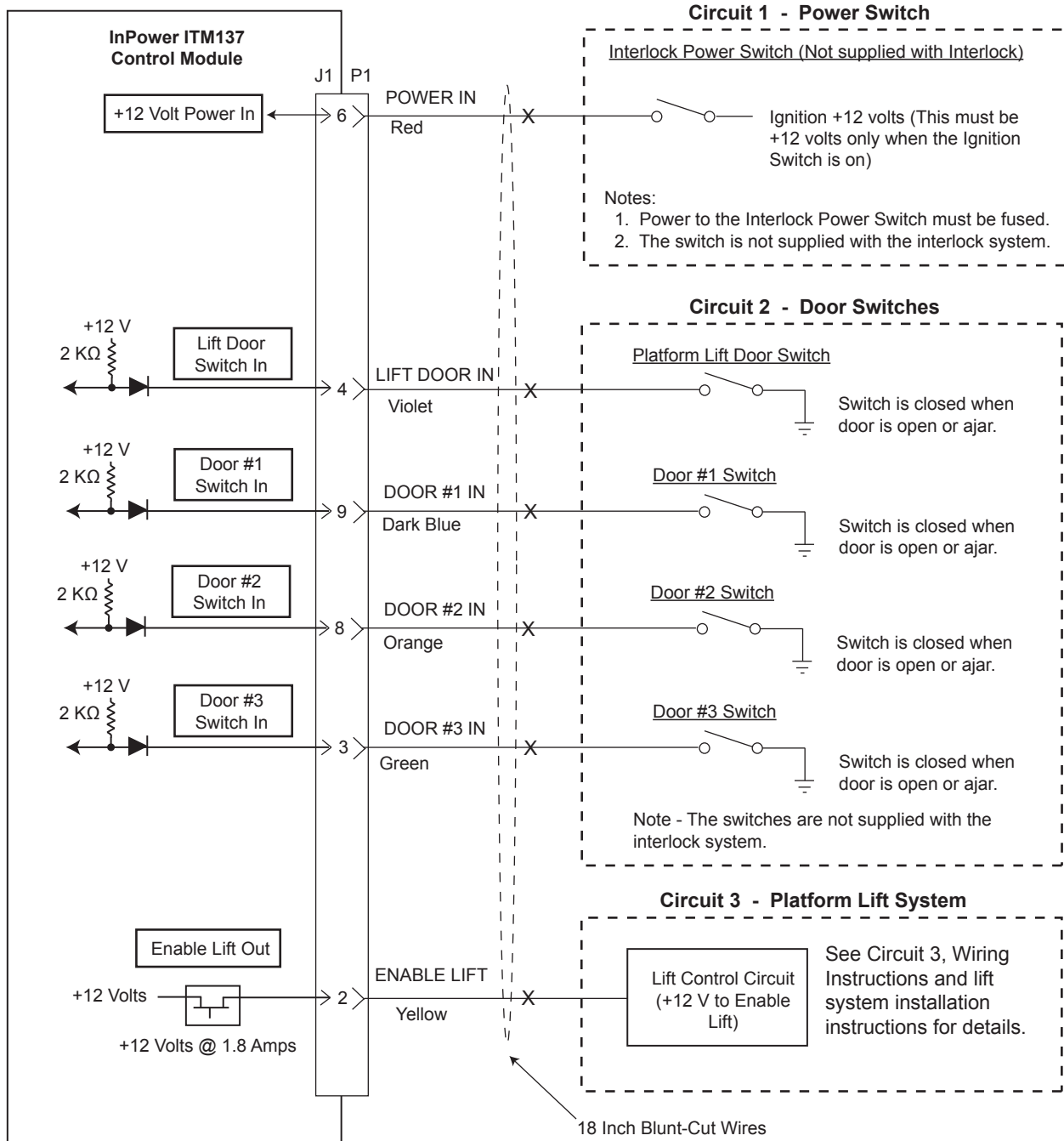

## 5. System Circuit Diagrams, Continued

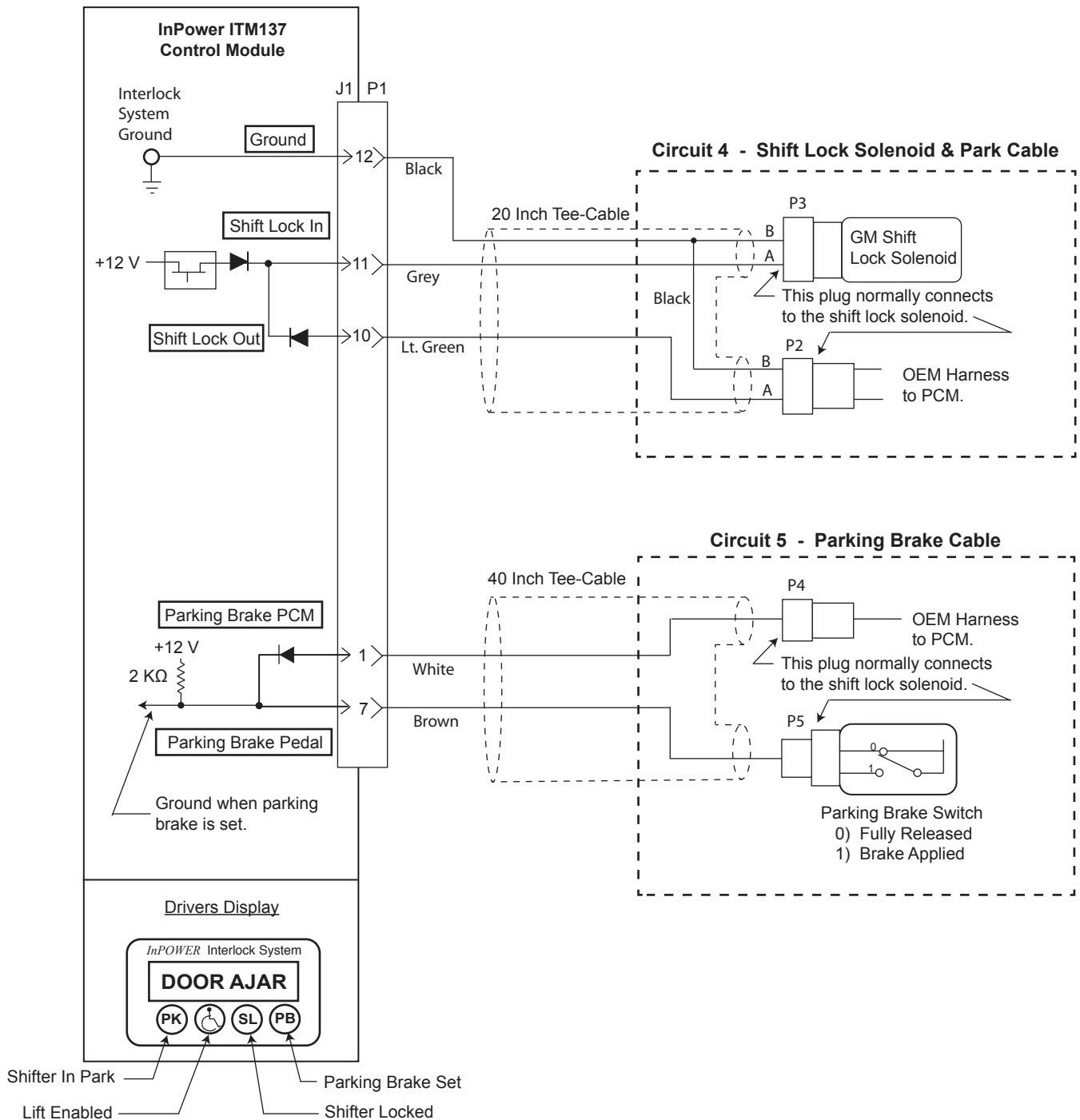

## 6. Installation Procedures

### 6.1 Safety Precautions



## WARNING

This interlock product has been designed and manufactured to meet the intended application requirements and specifications. Any modifications to the product or to the installation procedure can be dangerous and will void InPower's warranty.

- Read and understand the instructions in this manual and any other applicable manuals before starting the installation.
- Make sure that the vehicle battery power is disconnected during installation of the Interlock and lift systems.
- Reconnect the battery when the system installation is complete.
- Wear appropriate safety equipment, such as protective eyeglasses, face shield and clothing when installing equipment and handling the battery.
- Be careful when working near a battery. Make sure that the area is well ventilated and that there are no flames near the battery. Never lay objects on the battery that can short the terminals together. If battery acid gets in your eyes, immediately seek first aid. If acid gets on your skin, immediately wash it off with soap and water.

### 6.2 Getting Started

This manual provides instructions for installing the InPower Interlock System in a Chevy or GMC passenger van or cutaway chassis with a FMVSS compliant, public use (commercial) platform lift. It is important that you follow these instructions carefully and contact InPower if you need assistance or more information. Note that product technical documents are available on InPower's web site.



## WARNING

This interlock system installation requires additional parts and materials that are not supplied with the interlock product. Identify all required parts before starting the installation and ensure that these items are the correct type and quality (See Section 10.2).

Inspect the interlock product and all other components for damage before starting the installation. Do not perform the installation if any problems exist.

Determine the type of interlock interface required for the platform lift. This interlock system provides a +12 volt @ 1.8 amps Enable Lift output to allow the platform lift to be operated. If the lift system is not compatible with this interface signal you must take the necessary actions to adapt the lift system interface to the interlock system's interface. Refer to the lift manufacturer's installation instructions for further details.

The recommended mounting location for the interlock control module is on the dash, near the steering column, with the wiring harness through the dash. The wiring harness will connect to the shift lock solenoid and parking brake switch which are located under the dash on the driver's side. The unit must not be located in the engine compartment or any location that is not protected from the environment.

## 7. Wiring Instructions



# WARNING

Make sure that the vehicle battery power is disconnected during installation of the interlock and lift system. Re-connect the battery when the system installation is complete.

### Circuit 1 Wiring (Interlock System Power Switch and Ground)

The installer must supply a two-position On-Off Interlock power switch. This switch may be mounted on the dash at a convenient location. NOTE - An alternative method is to not use the Interlock Power Switch and wire the interlock module power input directly to a +12 volt fused power source that is powered by the Ignition Switch.

1. Mount the Interlock Power Switch.
2. Wire the “common” side of the Power On/Off switch to a properly fused +12 volt ignition switch source (powered when the ignition switch is On). Refer to the Chevy/GMC documentation for location of customer access ignition circuits.
3. Wire the “On” position side of the switch to the Red blunt-cut harness wire that goes to pin 6 of P1.
4. When complete, you should have +12 volt fused power on the interlock module connector P1 pin 6 when the ignition switch is On and the Interlock Power Switch is On.

**NOTE - Do not power the interlock system directly from the Battery or any power source that is not fused and turned off with the ignition switch.**

### Circuit 2 (Lift Door Switch and Optional Door Switches)

The interlock system contains four inputs for vehicle door switches. These switches are activated when a door is ajar or open, and applies a ground to the interlock system inputs. There are two methods of obtaining the door switch signals. The first method is to cut and splice into the GM door switch wires. Refer to Chevy/GMC documentation for details. The second method is to install new door switches dedicated to the interlock system. Note that the lift door switch signal is used for the interlock system’s logic, to operate the shift lock solenoid, and to operate the driver’s display flashing Door Ajar indicator. The three optional door switches will just operate the flashing Door Ajar indicator. Ensure that these switch signals apply a ground to the interlock input when the door is open/ajar. Wire the three optional door switches to the three blunt-cut wires as shown in Circuit 2. Wire the lift door switch to the Violet harness wire that goes to pin 4 of P1.

### Circuit 3 Wiring (Platform Lift)

Review the platform lift installation manual and determine how to wire the interlock system to the platform lift’s interlock interface. Note that the Enable Lift is a +12 volt OUTPUT from the interlock system and an INPUT to the lift system. When at +12 volts the platform lift can be operated. Install a wire from the platform lift’s Enable Lift input to the Yellow harness wire that goes to pin 2 of P1. Note - The interlock will supply a +12 volt @ 1.8 amp output to allow operation of the lift. Verify that this is the correct polarity for the platform lift.

### Circuit 4 Wiring (Shift Lock Solenoid Cable)

1. Locate the shift lock solenoid that is on the bottom left of the steering column behind the dash panel. It has a two-wire harness plugged into it.
2. Remove the harness plug from the solenoid assembly. **Do not pull on the wires as damage may result.**
3. Install the T-cable supplied with the interlock between the solenoid connector and the harness plug that you removed from the solenoid. When complete, the interlock T-cable will be connected to the OEM harness plug and the shift lock solenoid as shown in Circuit 4 diagram.

## 7. Wiring Instructions, Continued

### Circuit 5 Wiring (Parking Brake Switch Cable)

1. Locate the Parking Brake Switch connector that is near the parking brake pedal assembly. It has a single-wire harness plugged into it.
2. Remove the harness plug from the switch connector.
3. Install the T-cable supplied with the interlock wiring harness between the parking brake switch connector and the harness plug that you removed from the parking brake switch connector.
4. When complete, the interlock T-cable will be connected to the OEM harness plug and to the parking brake switch connector as shown in Circuit 5 diagram.

## 8. System Troubleshooting

This owners manual describes the InPower Model ITM137 Platform Lift Interlock Systems. Note that the control module contains an integral driver's status display which should be used for system troubleshooting. The interlock systems provide a Lift Enable signal output that is wired to the platform lift system to enable the lift operation when the chassis interlock conditions are satisfied. The Lift Enable signal is +12 volts when the lift can be operated.

### Replacement Parts

- |                                  |      |               |
|----------------------------------|------|---------------|
| 1. ITM137 Control/Display Module | P/N: | ITM137-MODULE |
| 2. Chassis Wiring Harness        | P/N: | 7201.049A     |

### Troubleshooting Procedures and Tips:

1. Determine if the interlock system is getting power. +12 volts should be present on the Red blunt-cut wire in the chassis wiring harness that goes to pin 6 on the control module's J1 connector. With power you should have some display lights on. See the circuit diagram on Page 4. Note that the interlock system gets its ground from the shift lock solenoid circuit on pin 12 of connector P1 (See Circuit 4 on Page 5).
2. If the interlock system has power and is not operating there is a high probability that the control module is good but that there is a problem with one or more of the system inputs (e.g., the Lift Door Switch not working correctly). Operate each remote door switch and determine if the correct display indicator operates properly. You can also measure voltage at the J1 connector pins to see if the remote devices are working correctly. A common problem on interlock systems is the lift door switch failing or sticking in the open position. This will cause the interlock system to not fully complete its cycle.
3. If the interlock system appears to be working properly but the platform lift system will not work check the voltage on the Lift Enable output to the lift system. This signal in on pin 2 of connector J1 (See Circuit #3 on Page 4). There should be +12 volts present to operate the lift. **CAUTION - Do not apply an external +12 volt power source to this circuit to see if the lift will operate without disconnecting the wire from the interlock system! Applying power will cause a circuit breaker to trip in the Lift Enable output circuit. If tripped, remove the power source and the circuit breaker will reset automatically.** With the Lift Enable wire disconnected from the interlock control module it is safe to apply +12 volts to the lift system's Lift Enable input to see if the lift will operate.



## 9. Mechanical Drawing

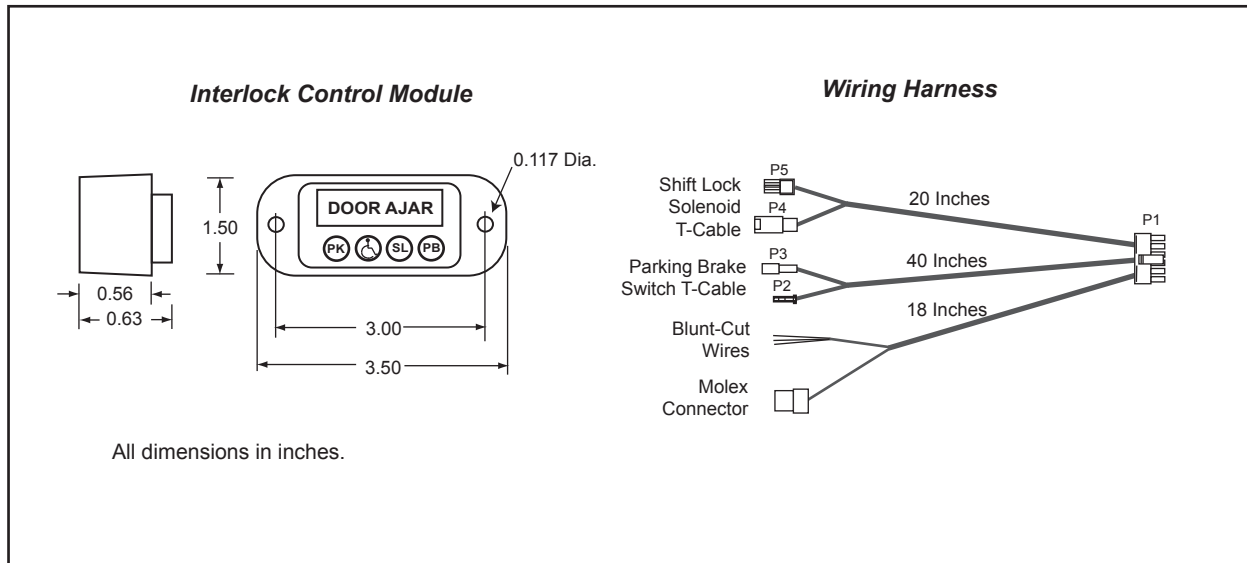

## 10. Reference Information

### 10.1 Company Contacts

GM Upfitter Integration  
[www.gmupfitter.com](http://www.gmupfitter.com)  
 Tel: 800-875-4742  
 Fax: 586-492-1085

The Braun Corporation  
 631 West 11th Street  
 Winamac, IN 46966  
 (574) 946-6153  
 (800) 946-6158  
[www.braunlift.com](http://www.braunlift.com)

Ricon Corporation  
 7900 Nelson Road  
 Panorama City, CA 91402  
 (818) 267-3038  
 (800) 322-2884  
[www.riconcorp.com](http://www.riconcorp.com)

Maxon Lift Corp.  
 11921 Slauson Avenue  
 Sante Fe Springs, CA 90670  
 (562) 464-0099  
 (800) 227-4116  
[www.maxonlift.com](http://www.maxonlift.com)

### 10.2 Required Parts Not Supplied with the Interlock System

1. Power switch and fuse. See page 4 , Circuit 1.
2. Lift door switch and door switches. See page 4, Circuit 2.
3. Miscellaneous wire, mounting hardware, wire tie wraps, wire loom.

This page intentionally left blank.