



VCM-04 Solid-State Off-Delay Timer Relay

InPower's VCM Series *Vehicle Control Modules* are a set of "tools" for the designers of vehicle electrical control systems. These solid-state modules are designed to withstand the environments typically found on trucks, emergency vehicles, buses, coaches and speciality vehicles, and are available in a variety of standard and custom configurations and functions.

Technical Description

The VCM-04 Series Off-Delay Timer is a completely solid-state timer relay with a +12 volt @ 15 amp output. The module contains two inputs, one activated by a transition to +12 volts (Input A) and one activated by a transition to ground (Input B). The two inputs operate as a logical Exclusive OR so that either input can operate the timer.

The output is activated when +12 volts is applied to Input A while Input B is off, or when ground is applied to Input B while Input A is off. The timer starts when the input signal is removed. When the timer expires the output is turned off and the operation is complete. Fixed and adjustable time settings are available. Adjustable time values are set using a single-turn potentiometer. See the *Ordering Guide* for the standard models.

Key Features

- 100% Solid-State Construction
- Standard Automotive Relay Pin Format
- 12 Volt 15 Amp Solid-State Output
- Compact Size with Panel-Mount Bracket
- Dual Inputs (Ground and +12 Volt Actuated)
- Durable Metal Case

Ordering Guide

Model	Time Range	Model	Time Range	Model	Time Range
VCM-04-01SA	0-1 Second Adjustable	VCM-04-60SF	60 Seconds Fixed	VCM-04-10MA	0-10 Minutes Adjustable
VCM-04-05SF	5 Seconds Fixed	VCM-04-02MA	0-2 Minutes Adjustable	VCM-04-15MF	15 Minutes Fixed
VCM-04-10SA	0-10 Seconds Adjustable	VCM-04-03MA	0-3 Minutes Adjustable	VCM-04-20MF	20 Minutes Fixed
VCM-04-10SF	10 Seconds Fixed	VCM-04-03MF	3 Minutes Fixed	VCM-04-60MA	0-60 Minutes Adjustable
VCM-04-60SA	0-60 Seconds Adjustable	VCM-04-05MF	5 Minutes Fixed	VCM-04-03HA	0 - 3 Hours Adjustable

System Diagram

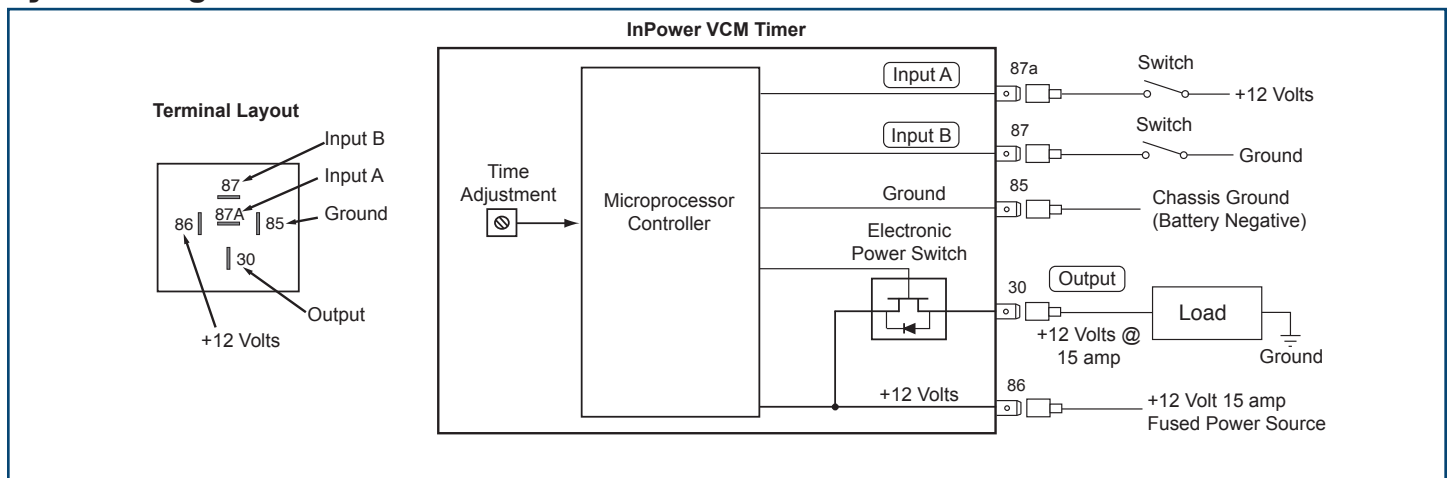

Specifications

Power Input (86):	+8 to +16 Vdc, 15 Amps max.
Ground (85):	Connection to vehicle ground (Battery Negative)
Input A (87a):	On = >4.0 V, Off = <2.5 V
Input B (87):	On = <2.0 V, Off = >3.0 V
Module Output (30):	+12 volts @15 amps, with over current fault shutdown
Mechanical	
Dimensions:	2.30 W x 1.75 H x 1.25 D inches
Case Material:	Anodized aluminum
Operating Temperature:	-40° C to +85° C
Weight:	0.10 lbs.

Timing Diagram

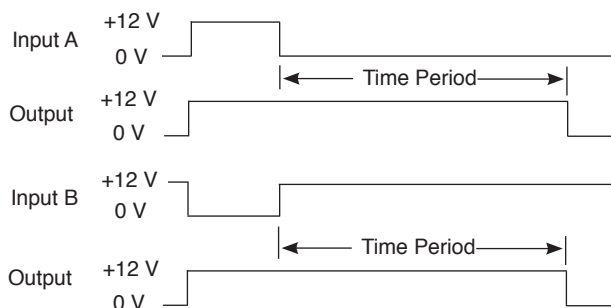

Installation

1. We recommend that the module be installed by a person trained and skilled in vehicle electrical systems. The installation should comply with SAE (Society of Automotive Engineers) and the vehicle manufacturer's electrical wiring procedures (e.g., Ford General Motors, etc.).
2. The module should be installed inside the vehicle in a dry and protected environment.
3. For optimum performance the module should be mounted to a flat metal surface.
4. Do not connect loads to the outputs that will exceed the output current rating of the module.
5. The power input (BAT+ terminal) must be wired to a fused +12 volt battery power source.
6. Wiring must be of the proper gauge and type to handle the intended load currents.
7. Use ¼ inch female blade terminals to connect wires to the terminals on the module. Be sure to properly crimp these terminals. **Do not solder wires directly to the module terminals.**
8. If you are experiencing problems with the installation or need troubleshooting assistance, contact InPower Customer Service at 740-548-0965.

Mechanical Drawing

