



VCM-08 Dual 15 Amp Alternating Lamp Flasher

InPower's VCM Series *Vehicle Control Modules* are a set of tools for the designers of vehicle electrical control systems. Designed to withstand the environments typically found on trucks, emergency vehicles, buses, coaches and speciality vehicles, these modules are available in a variety of standard and custom configurations and functions.

Technical Description

The InPower VCM-08 warning lamp flasher is a compact, high performance flasher with exceptional reliability and low cost.

The VCS-08 flasher is a completely solid state dual output alternating arning lamp flasher. Its outputs are rated at +12 volts @ 15 amps each, and are designed to operate high in-rush current halogen and incandescent lamps, as well as LED lights.

When a ground is applied to the input, the outputs will alternately flash at a rate of 75 cycles per minute at a 50% duty cycle. The solid state outputs will automatically shut off if an over current or short circuit fault occurs. If a fault shut down occurs on one output the other output will remain operational.

Key Features

- 100% Solid State Construction
- Operated Halogen and LED Lights
- Standard Automotive Relay Pin Format
- Dual 12 Volt 15 Amp Solid-State Outputs
- Compact Size With Panel-Mount Bracket
- High Technology Power Switching Clrcuit
- Durable Metal Case

Ordering Guide

Model	Description
VCM-08	Solid-state alternating lamp flasher with single input and two +12 volt @ 15 amp outputs.

System Diagram

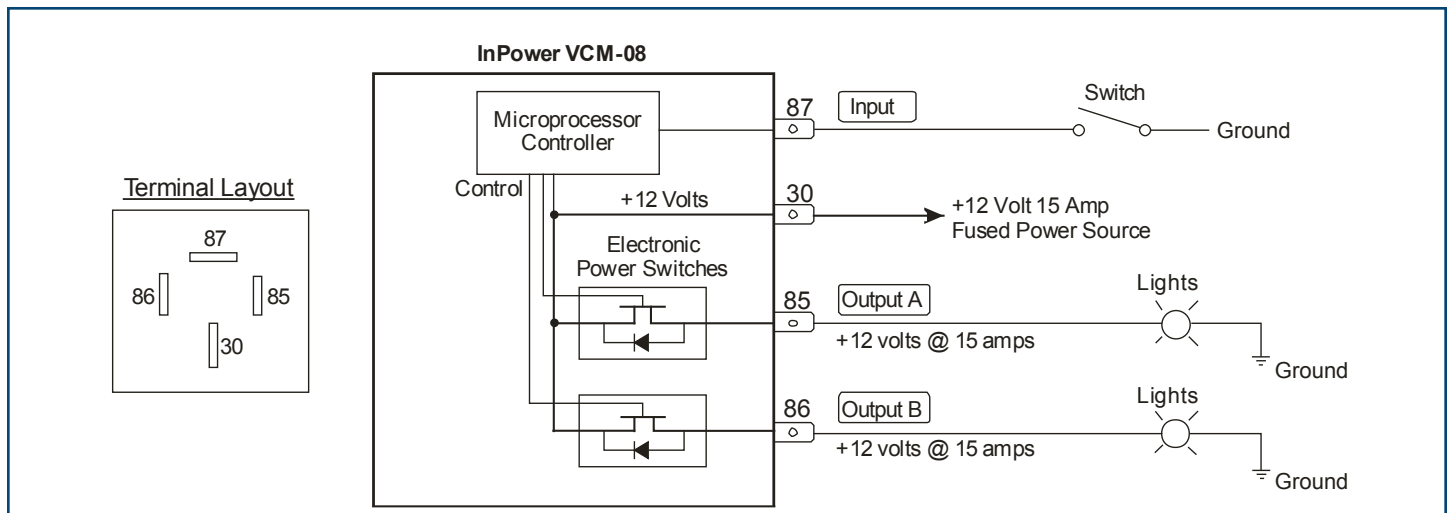

Specifications

Power Input (30):	+8 to 16 Vdc @ 15 amps
Control Input (87):	External contact closure to ground
Output A (85):	+12 volts @ 15 amps
Output B (86):	+12 volts @ 15 amps
Flash Rate:	75 per minute

Mechanical	
Weight:	0.10 lbs.
Operating Temperature:	-40° C to +85° C

Timing Diagram

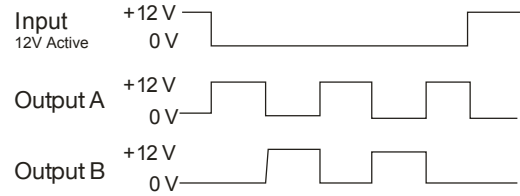

Installation

1. We recommend that the module be installed by a person trained and skilled in vehicle electrical systems. The installation should comply with SAE (Society of Automotive Engineers) and the vehicle manufacturer's electrical wiring procedures (e.g., Ford, General Motors, etc.).
2. The module should be installed on the inside of the vehicle in a dry and protected environment.
3. For optimum power output performance the product should be mounted to a metal surface.
4. Do not connect loads to the output that will exceed the output current rating of the module.
5. The 12 volt power input (30) must be from a properly fused +12 volt power source.
6. Wiring must be of the proper gage and type to handle the intended load currents.
7. We recommend the use of insulated 1/4 inch female blade terminals that connect to the terminals on the module. Be sure to properly crimp these terminals. **Do not solder wires directly to the module terminals.**
8. If you are experiencing problems with the installation or need troubleshooting assistance, contact InPower Customer Service at 740-548-0965.

Load Considerations: Relays/Solenoids must incorporate Fly Back Suppression Diodes/Circuitry. These Relays/Solenoids (without suppression) can create large voltage and current spikes which damage electronics. Having inductive loads without suppression violates your unit's warranty and may damage your vehicles electronics!

Mechanical Drawing

