

VCMR2-24V

Programmable Dual 24V Latching Relay



Technical Description

This VCMR2-24V module is similar logically to the RX-0302 series of products but with the addition of two Form-C relay outputs instead of the 12Vdc or GND output. In addition, this design is modified to run on 24Vdc instead of 12Vdc. Most of the common Off-Delay, On-Delay or OneShot Timer software can easily be converted to operate in this module.

Custom programs will have some VCMR2-SPCnnn number assigned when the definition is established by engineering and a customer.

Below is a brief description of each of the VCMR2 terminals:

BAT : This is the +24Vdc power supply to operate the VCMR2. Operating Voltage range is 10-15Vdc. Current requirements are 0.010 amps when the relay is off and 0.175 when the relay is on.

GND : This is the VCMR2 power supply ground. Current requirements are 0.010 amps when the relay is off and 0.175 when the relay is on.

IN1, IN2, and IN3: These Logic inputs are used for the VCMR2 logic functions which control the Relay Outputs. They can be either is 24Vdc = True, or GND = True like the RX functions.

30-1 and 30-2 : These are the common wipers of the Form-C Relay output circuits. Load circuit to be fused by installer at 15 amps or less.

87A-1 and 87A-2 : These are the normally closed contacts of the Form-C Relay circuit. Load circuit to be fused by installer at 20 amps or less. When the logic of the VCMR using inputs I-1 and/or I-2 is true this terminal will disconnect from terminal 30.

87-1 and 87-2 : These are the normally open contact of the Form-C Relay circuit. Load circuit to be fused by installer at 15 amps or less. When the logic of the VCMR2 using IN1, IN2, and IN3 as programmed is TRUE this terminal will connect to terminal 30.

Key Features

- Factory programmable for a wide variety of responses based on the 3 Inputs to activate the Relays.
- Provides a Programmable response based on the three Inputs, logical functions, timers, delays, flashers
- Low cost with fast and easy installation.
- Fastons for easy integration and troubleshooting

System Diagram

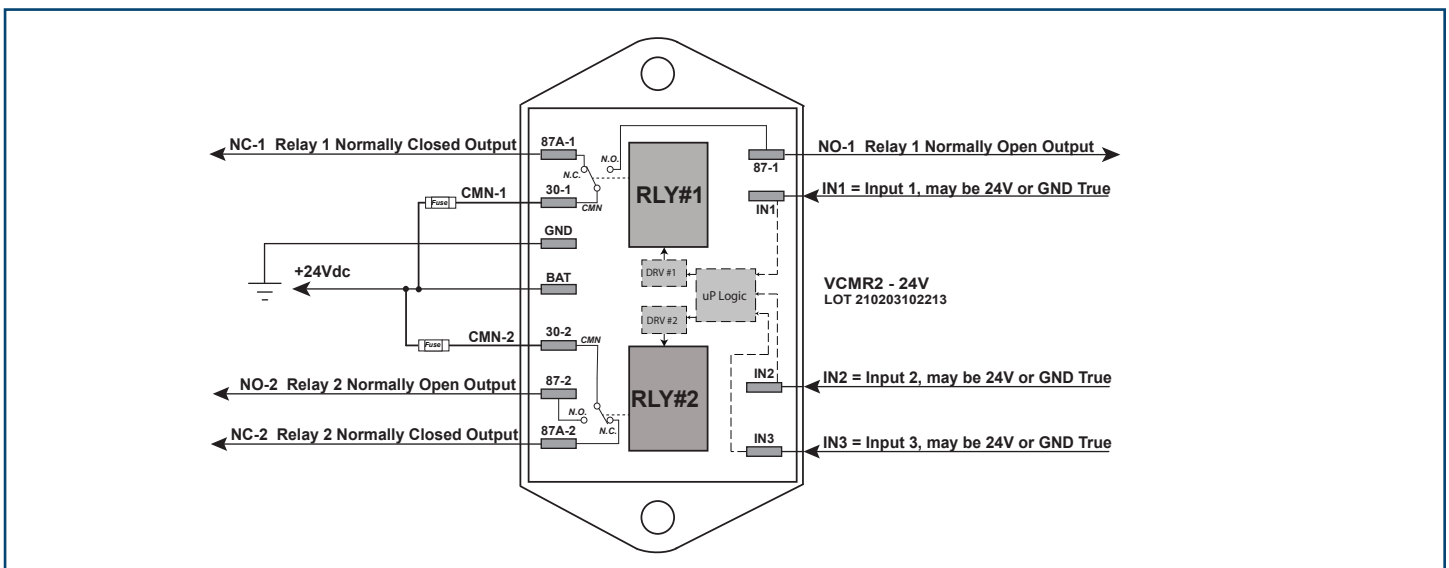

Specifications

Programming

Programming and operation of the VCMR2-24V Programming Dual Latching Relay Module is programmed for operation by InPower. We work with the customer to establish the response of the module to the three (3) independent Inputs, IN1, IN2, and IN3. The conditions on these Inputs will then dictate the operation of the 2 Form C relays as defined by the customer and InPower.

Inputs can be from a active high (True) voltage, or a active low (True) voltage such as a ground.

There are combinatorial functions such as AND, OR, NOT, Timers, Delays, Toggling (Flashing) at a given rate, other special functions that can be defined working with the customer and InPower.

Interface and Control

Inputs:

BAT: (PWR) Sourced from fused Ignition source. Operating Voltage range is 15-35VDC

GND: (GND) Sourced a Good Solid Battery Ground. Current Requirements are 0.010 Amps (10mA) when the relays are OFF and 0.175 Amps (175mA) when the relays are ON.

IN1: (Input) True is defined as greater than 6.0Vdc, and False as less than 4.0Vdc

IN2: (Input) True is defined as greater than 6.0Vdc, and False as less than 4.0Vdc

IN3: (Input) True is defined as greater than 6.0Vdc, and False as less than 4.0Vdc

SPDT Relay Common Terminals:

30-1: Common Wiper of the Form-C Relay output circuit for Relay #1. The feed to load circuits must be fused by the installer at 15 Amps or less and connected to +24.0Vdc.

30-2: Common Wiper of the Form-C Relay output circuit for Relay #2. The feed to load circuits must be fused by the installer at 15 Amps or less and connected to +24.0Vdc.

Relay Form-C Outputs:

87A-1: Relay #1 - This is the Normally CLOSED contact of the Form-C Relay circuit. This circuit is the resting state of the relay where 87-A-1 is connected to 30-1.

87A-2: Relay #2 - This is the Normally CLOSED contact of the Form-C Relay circuit. This circuit is the resting state of the relay where 87-A-2 is connected to 30-2.

87-1: Relay #1 - This is the Normally OPEN contact of the Form-C Relay circuit. This circuit is the energized state of the relay where 87-1 is connected to 30-1

87-2: Relay #2 - This is the Normally OPEN contact of the Form-C Relay circuit. This circuit is the energized state of the relay where 87-2 is connected to 30-2

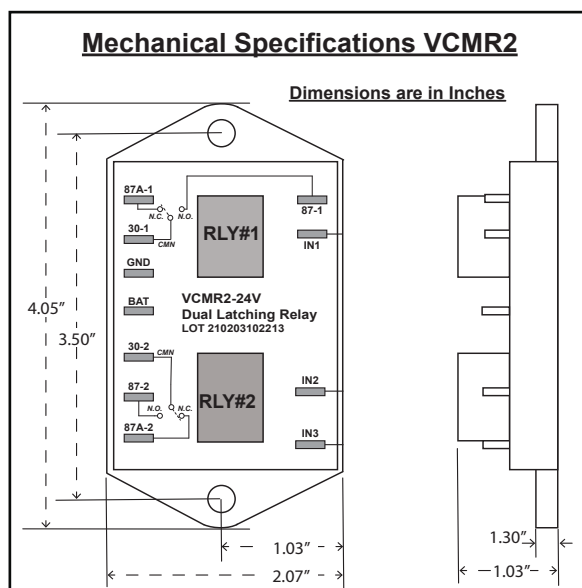

Mechanical Specifications

Dimensions: 4.05 L x 2.07 W x 1.03 H inches

Operating Temp: -40°F to 185°F