

VCMS2-SM6

6 Button Switch Module with Molex Connectorization

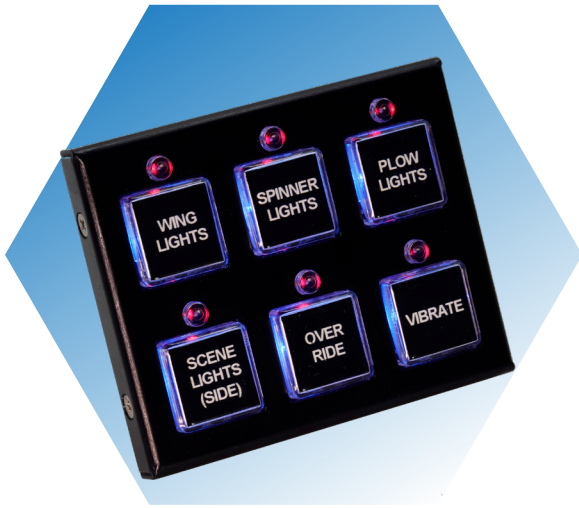

Technical Description

The Model VCMS2-SM6 Switch Module is a component of the InPower's second generation Vehicle Control Module System (VCMS2), a modular, programmable switch panel system used for controlling 12 volt auxiliary devices on vehicles. The system can be configured for a wide range of applications controlling devices such as lights, beacons, fans, compressors, and other 12 Vdc devices.

The switch module easily networks with switch modules and power modules through an eight pin Molex-150 connector. Switch modules may be arranged in a master / slave arrangement or independantly. Any Slave modules (up to 2 Slaves) can have replicated switch functions allowing the same function to be controlled from separate module locations (2 or 3 different switches - Mirrored).

All power modules and switch panels connect via an 8 pin Molex-150 sealed connector and may be daisy-chained to accomodate extra modules and panels. Switch modules mount to a panel with four 6-32 threaded studs and is intended for interior vehicle locations.

Each switch position may be programmed to be momentary, two-position latching or three-position latching. All switches are backlit and each has a status LED. Legends are available in both standard and custom formats, and are easily replaced.

Key Features

- Thin Profile
- Backlit Switches
- Custom and Standard Legends
- Modular/Expandable Design
- Switch Status Indicators
- Programmable Functions
- Easy to install cable

System Diagram

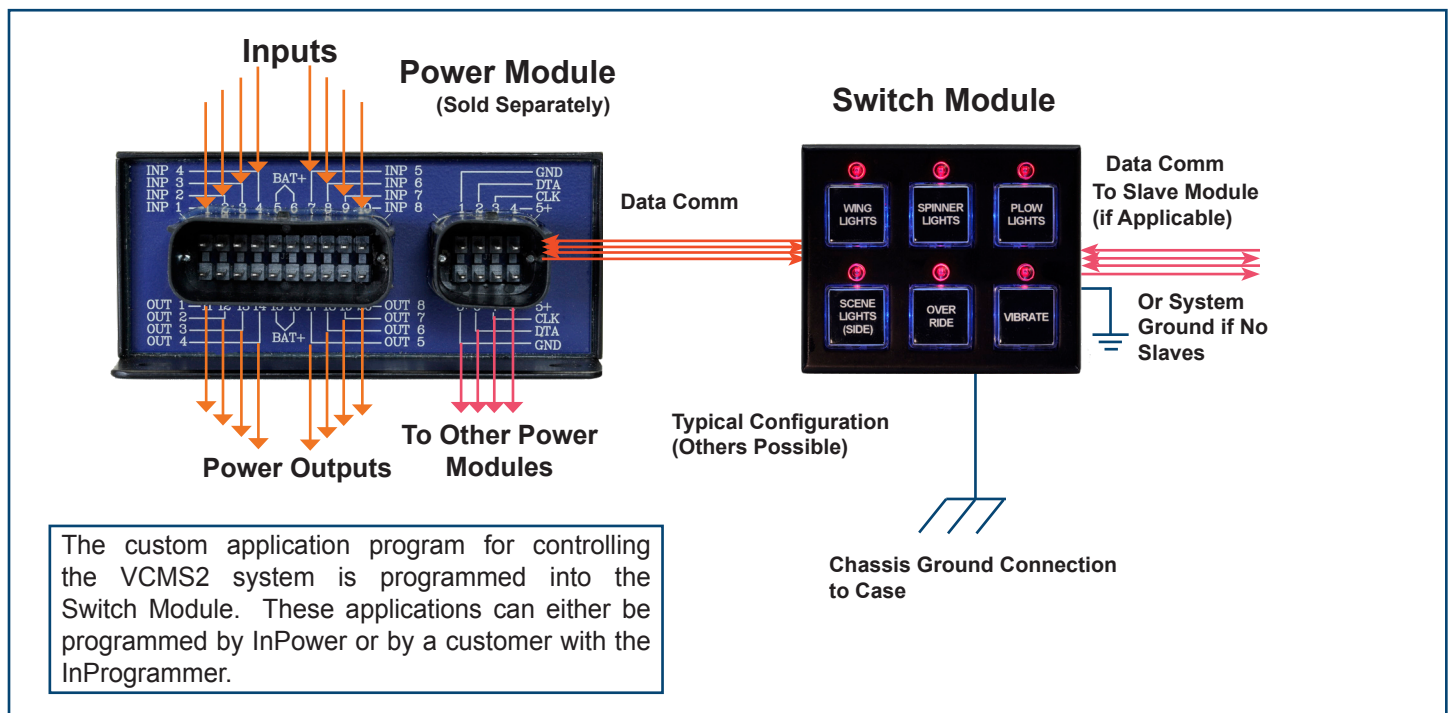

Specifications

Dimensions:	2.74 inch H x 3.33 inch W x 0.55 inch D
Case Material:	Anodized aluminum
Mounting:	Four 0.68 inch #6-32 threaded studs
Mating Connectors:	One 8 pin A key Molex 150 (part # 33472-0806): ground and data between modules
Status Indicator:	Red LED
Back Light:	Blue
Switch Cap:	Molded plastic with legend label and light diffusor
Switch Functions:	Programmable as Momentary, 2-position latching (Off-On1), or 3-step (Off-On1-On2)
Switch Legends:	Custom legends available or select from InPower's standard switch legend library, document TB-59.

Mounting Template Mechanical Drawing

