

ITM127 ITM127-E21

Platform Lift Interlock

Ford Platform Lift Interlock System



Ford Interlock System for monitoring plat- form lift door and up to three auxiliary doors

Technical Description

InPower's Model ITM127 interlock system provides the required FMVSS 403/404 interlock functions for public-use platform lifts installed in 2021 Ford E-series* van and cutaway chassis. The systems consist of a combined driver's display and control module as well as an easy-to-install plug-and-play chassis wiring harness.

The wiring harness includes a set of blunt cut wires for connecting to the platform lift system door switches and 12 volt power and T-cables for interfacing with the Ford shift lock solenoid, park signal and parking brake switch. The interlock's Lift Enable output is rated at +12 volts @ 1.8 amps, and it is compatible with current production platform lifts manufactured by Braun, Ricon and Maxon.

Key Features

- Supports 2021 E Series Ford Van and Cutaway Chassis
- Combined Driver Display and Control Module
- Large Flashing Door Ajar Indicator
- Status / Diagnostic Indicators
- Monitors up to Four Door Switches
- Plug-and-Play Wiring Harness
- Direct Interface to Platform Lift Systems

The driver display includes a two-inch flashing Door Ajar indicator as well as indicators for Park, Park Brake, Shifter Locked and Lift Enabled. The interlock monitors the lift door and up to three auxiliary doors. For model ITM127, if any of these doors are not fully closed, the display's Door Ajar indicator will flash.

*Additional models are available for F-Series vehicles.

System Diagram

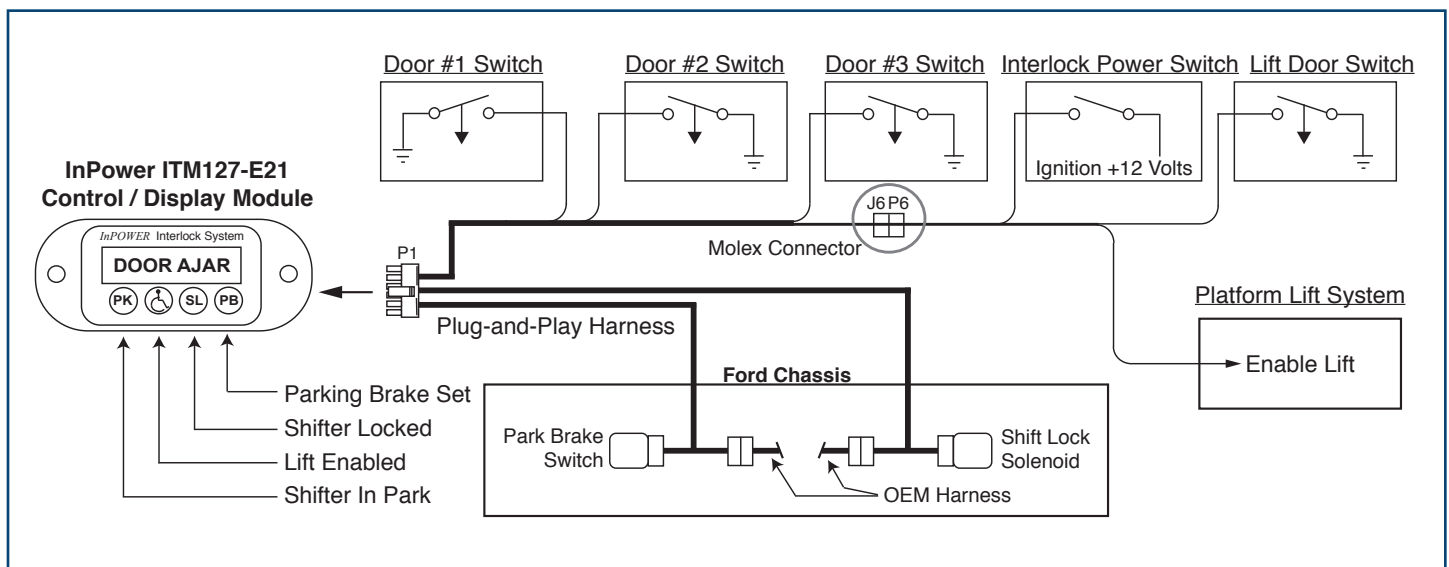

Specifications

Module Inputs

Power Input:	+8.0 Volts to 16 Volts @ 2 amps. Requires a fused power source that is powered when the ignition switch is on. (ITM127: Blunt-cut Red)
Lift Door In:	From lift door closed switch. Ground when door is open/ajar. (ITM127: Blunt-cut Violet)
Door #1 In:	From Door #1 closed switch. Ground when door is open/ajar. (Blunt-cut Blue)
Door #2 In:	From Door #2 closed switch. Ground when door is open/ajar. (Blunt-cut Orange)
Door #3 In:	From Door #3 closed switch. Ground when door is open/ajar. (Blunt-cut Green)

Module Output

Lift Enable:	+12 volts @ 1.8 amps to allow platform switch operation. (ITM127: Blunt-cut Yellow)
--------------	---

Mechanical

Dimensions:	3.50 W x 1.50 H x 0.56 D inches
Weight:	0.15 lbs
Operating Temperature:	-40° C to +85° C

Available Models

ITM127-E21	Ford E-Series van and cutaway. Note: chassis cabs require a different harness
ITM127-F	Ford F-Series

Please see owner's manuals for detailed cable information.

Mechanical Drawing

