

VCMS Input/Output Diagram VCMS-SM10 & VCMS-PM1

VCMS-SM10 Switch Module

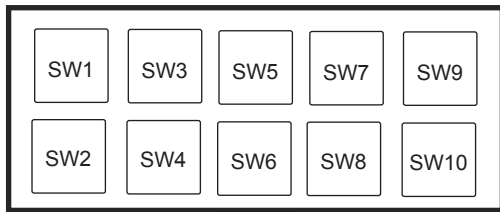

Switch Functions/Legends

SW1 ()	SW3 ()	SW5 ()
SW2 ()	SW4 ()	SW6 ()
SW7 ()	SW9 ()	
SW8 ()	SW10 ()	

Key:
M = Momentary
2 = Off-On1
3 = Off-On1-On2

Logic Cable -
Length _____ ft.

System Inputs

VCMS-MOD1 Power Module

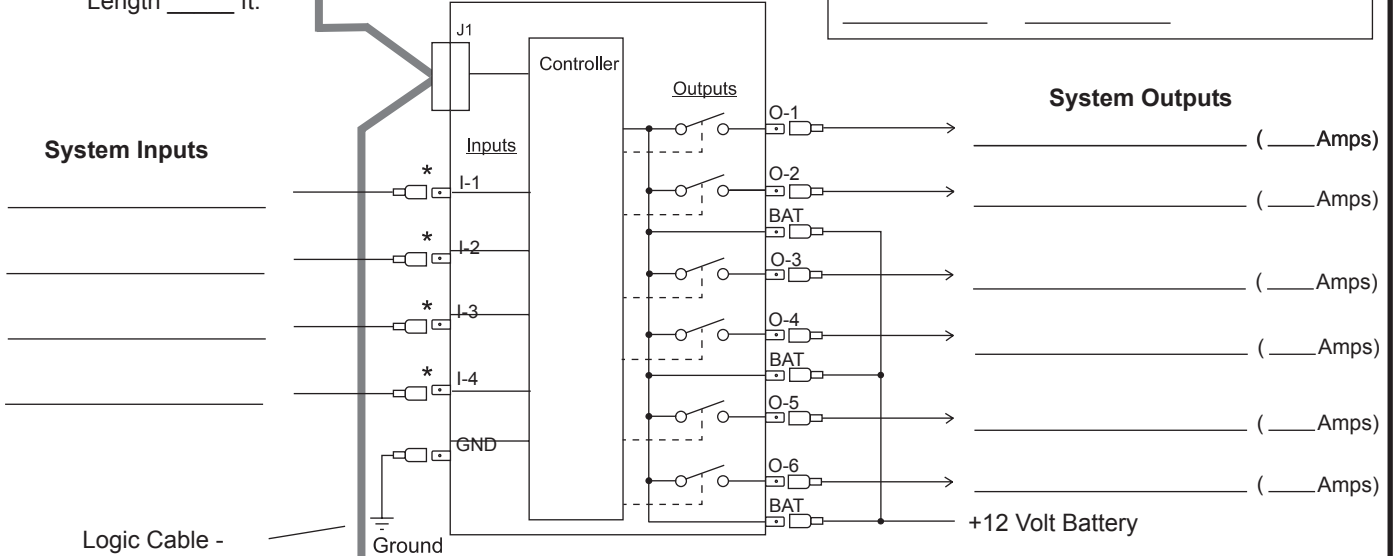

Logic Cable -
Length _____ ft.

System Inputs

VCMS-MOD2 Power Module

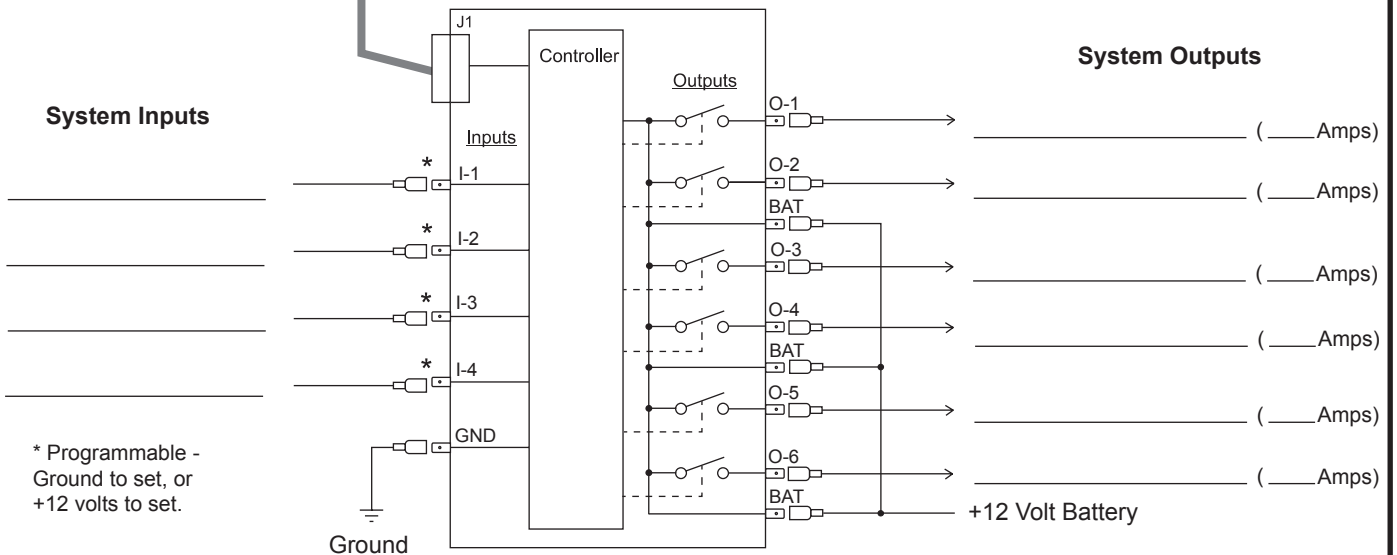

* Programmable -
Ground to set, or
+12 volts to set.

Customer: _____ Project: _____ Spec. Spec No: _____ Date: _____