

OWNERS MANUAL Data Bus Throttle for

Light Duty Ford and GM Vehicles

Models:

DBT-LD-01

DBT-LD-02

DBT-LD-03

DBT-LD-04

For other years of Ford Vehicles see:

http://www.inpowerelectronics.com/throttle_selector

Caution! Not to be used for PTO Applications! (See Sec 3.2.5)

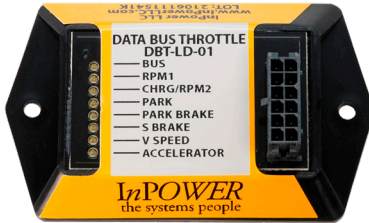

1. Product Description

InPower's DBT-LD Data Bus Throttle provides high idle engine RPM control for light-duty vehicles. The control module connects to the vehicle's OBD-II diagnostic connector via a cable with a pass-through OBD-II connector for any other OBD-II access. The cable also includes blunt-cut wires for the operating mode inputs, the high idle active output signal, and the speed adjustment.

Four light duty models are available, each providing two operating modes:

- DBT-LD-01** Adjustable Preset 1 and *Green Charge*. Inputs activated by ground. Preset 1 has priority.
- DBT-LD-02** Adjustable Preset 1 and Preset 2. Inputs activated by +12 volts. **Preset 2** has priority.
- DBT-LD-03** Adjustable Preset 1 and *Green Charge*. Inputs activated by +12 volts. Preset 1 has priority.
- DBT-LD-04** Adjustable Preset 1 and On/Off Charge Protect. Inputs activated by ground. Preset 1 has priority.

Note: Modules are programmed to prevent high idle unless the Chassis Ready Conditions are satisfied. (See Section 4)

LED diagnostic indicators are provided to aid system troubleshooting. These indicators are located on the top of the module. (See Sections 5 and 6)

InPower provides product customization for the DBT-LD Series throttles. These units will carry a DBT-LD-C model designation followed by a SPC number. The custom functions may deviate from this manual and may incur additional programming fees.

1.1 Preset

When PRESET is activated, the engine idle is raised to a present RPM. The default RPM is 1500 for Preset 1. The DBT-LD-02 has a Preset 2 instead of a Green Charge or On/Off Charge Protect. The default RPM for Preset 2 is 900. Preset 1, Preset 2, and On/Of charge Protect may be adjusted. (See Section 4.) Preset 1 overrides Preset 2, Green Charge, and On/Off Charge Protect.

1.2 Green Charge

When InPower's *Green Charge* is active, the engine idle is raised to 900 RPM. The DBT module then gradually raises the engine speed from 900 RPM to the minimum speed necessary to charge the batteries. Once the batteries are charged, the Green Charge mode will hold the engine idle at the minimum RPM necessary to maintain the charge, maximizing fuel economy and minimizing emissions.

1.3 On/Off Charge Protect

On models with the On/Off Charge Protect mode, the engine is cycled between 900 and 1500 RPM as needed to keep the battery charged. The preset modes will elevate the engine to pre-adjusted RPM. On standard models and most custom models, the preset mode values can be field adjusted. Some custom models may have the field adjustable feature locked out.

2. Vehicle Applications

InPower designs the DBT's software to support many chassis and model year variations, and more will be added to the library as they are tested. To verify that your model is supported, please visit our Throttle Selector Guide on our web site (www.InPowerLLC.com). Enter the chassis and model year, and it will display the minimum software revision required for your chassis.

The software revision letter is the character following the throttle's 10 digit LOT code located on the label. If there is an SPC number, "SPC###" will be after the software letter. The DBT-LD throttle is re-programmable, and older models may be able to have their software updated (additional fees may apply).

The DBT-LD throttle detects and stores the vehicle type during the first ignition turn-on after installation. If the PARK LED is on solid and all other LEDs are off this indicates the throttle has not identified the vehicle or the vehicle is not supported. Turn on the ignition and leave it on for at least two minutes. If the PARK LED is still on solid, the vehicle may not be supported.

Note that the throttle will need to re-detect vehicle type if at any point it loses power, such as if it is disconnected from the OBD-II port or the vehicle's battery is removed. Likewise, if it is moved to a new vehicle, when first connected to this new vehicle, it will detect the chassis type.

3. Installation Procedures

3.1 Safety Precautions



WARNING



This electronic throttle product has been designed and manufactured to meet the intended application requirements and specifications. Any modifications to the product or to the installation procedure can be dangerous and will void InPower's warranty.

- Read and understand the instructions in this manual and other manuals before starting the installation.
- Make sure that the vehicle battery power is disconnected during installation of the throttle module.
- Reconnect the battery when the system installation is complete.
- Wear appropriate safety equipment, such as protective eyeglasses, face shield and clothing when installing equipment.
- Be careful when working near a battery. Make sure that the area is well ventilated and that there are no flames near the battery. Never lay objects on the battery that can short the terminals together. If battery acid gets in your eyes, immediately seek first aid. If acid gets on your skin, immediately wash it off with soap and water.

3.2 Getting Started

3.2.1. The recommended location for the DBT throttle module is under the dash due to the proximity of the wiring connections and cable length. **Do not locate the unit in the engine compartment or any location that is not protected.** You will need a crimping tool and terminals to terminate wires to the provided blunt-cut wires.

3.2.2. Mount the DBT throttle under the dash using two #6-32 screws. Ensure that you have sufficient distance to install the supplied data bus cable. **Do not extend the length of or otherwise alter this cable or the warranty will be void!**

3.2.3. Install the data bus cable. One end plugs into the 12-pin connector on the DBT throttle module. The other end contains the three OBD-II connectors. Detach the OBD-II connector that is mounted at the lower part of the dash and plug it into the male OBD-II connector on the data bus cable. Use the male and the female connector that works best for your installation and secure the un-used one with a tie wrap/clamps. Install the OBD-II connector you are using (with the mounting tabs) on the dash. Secure the cable with tie wraps and/or cable clamps.

3.2.4. Wire the customer-supplied speed mode inputs. These may be switches or wiring from circuits that supply +12 volts (or ground) when the desired mode is to be activated. See System Diagram (Section 8) for wiring

the mode switches. Select the correct DBT-LD model in the diagram and wire the switch labeled To RPM1 to the Brown RPM1 Input blunt-cut wire. Wire the switch labeled To RPM2 to the Violet RPM2 Input blunt-cut wire. Be sure that the switches are wired to the +12 volts or ground per the diagram.

3.2.5. If needed, wire the High Idle Active Output. This is the Orange blunt-cut wire in the Data Bus Cable. The High Idle Active Output supplies +12 volts @ 3 amps when: A) a speed mode input is set, B) all Chassis Ready Condition are satisfied, and C) the elevated idle speed request has been sent to the engine controller. This can be used, for example, to operate a clutch pump, air compressor or power inverter. **Do not use this output to operate any transmission mounted PTO. Make sure you do not overload this output. If more current is necessary, use a relay to supply the added current.**

3.2.6. The installation is now complete. Start the engine and activate the Preset and Auto modes switches to verify proper operation. If the elevated idle speeds' default values need changing you will need to calibrate the preset speed. (See Section 4 for *Preset Speed Adjustment* instructions). If the system does not operate properly refer to Sections 5 and 6 for Troubleshooting and LED Diagnostic Indicators.

See Section 8 on page 11 for System Diagram.

4. Operation

Each DBT-LD will come with two of the following modes (refer to the System Diagram on Page 11 to see which modes are available on each model):

Note: None of the modes will activate if the Chassis Ready Conditions are not met.

Preset Mode - The engine speed increases to a pre-adjusted preset speed value. Note that Model DBT-LD-02 has two individually adjustable presets, Preset 1 and Preset 2.

Green Charge Mode - When activated, raises the engine idle speed to 900 RPM and then gradually raises the speed to the point necessary to maintain battery charge. As the DC load varies on the truck, the RPM will raise or lower to maintain charge, maximizing fuel economy and minimizing emissions. The Green Charge is available on Models DBT-LD-01 and DBT-LD-03.

On/Off Charge Protect Mode - When the battery voltage is low, the throttle automatically increase the engine speed to 1,500 RPM for faster battery charging. It returns the engine speed to 900 RPM when the battery voltage indicates a normal charge. This mode is only available on Model DBT-LD-04.

Chassis Ready Conditions:

- No vehicle speed
- Parking brake set
- Shift selector in Park
- Accelerator not depressed
- Service brake not depressed
- Engine running and below 1,000 RPM
- No Diagnostic Trouble Code (DTC). Check Engine light must be off.

Preset Speed Adjustment: To change the preset speed RPM value, activate the desired preset mode. When the engine speed has changed to the preset value, apply either +12 volts or ground to the Speed Adjust Mode blunt-cut cable wire. Apply + 12 volts to the adjustment wire to increase the speed or a ground to decrease speed. The engine speed will change at a rate of 50 or 100 RPM per second. Remove the +12 volt or ground when the desired speed is obtained. The high idle engine speed can be adjusted in the On/Off Charge Protect mode. Perform the above procedure when in the On/Off Charge Protect mode and when it is at the elevated idle speed.

Once desired RPM is set, tape the gray wire to the wiring harness to prevent accidental speed changes if wire should make contact with a ground.

Note that the *Green Charge* speed mode is not manually adjustable.

5. Troubleshooting

5.1. *For new installations.* The throttle automatically checks to see if its software revision code supports the chassis. The DBT-LD throttle detects and stores the vehicle type during the first ignition turn-on after installation.

If the PARK LED is on solid and all other LEDs are off, either the throttle has not identified the vehicle, or the vehicle is not supported. Turn on the ignition and leave it on for at least two minutes. If the PARK LED is still on solid, the vehicle is not supported. If the throttle is not supported, go to InPower's web site (www.InPowerLLC.com) and look up your chassis in the Throttle Selector Guide to verify the required software revision.

5.2. Check all wiring and make sure all connectors are plugged in firmly.

5.3. Check the LED diagnostic indicators. Refer to the LED Diagnostic Indicator table or the flow chart (Section 6) to determine where the fault is. The chart shows the various combinations of status indicator states and what they indicate about the throttle operation. Note that each LED can be Off, On Solid, Blinking at a slow rate or Flashing at a fast rate.

5.4. The default engine speed refers to state when all RPM inputs are true. RPM1 is the default engine speed on DBT-LD-01, DBT-LD-03, and DBT-LD-04. The default engine speed on the DBT-LD-02 is RPM2.

If you are referring to the table, find the row of the chart that matches and look under the 'Throttle Operation' column to determine the fault condition. If you are referring to the flowchart, start where indicated and follow the paths corresponding to your answers to the various questions to determine the fault condition. We have provided both methods to aid both those who prefer tables and those who prefer a more visual approach.

6. LED Diagnostic Indicators

| LED states: Off - LED off On - LED on solid Blink - LED flashing slowly Flash - LED flashing quickly | | | | | | | | | |
|--|-------|-------|-------|------------|------------|---------|-------|---|------------|
| BUS | RPM | CHRG | PARK | PARK BRAKE | SERV BRAKE | V-SPEED | ACCEL | THROTTLE OPERATION | ENGINE RPM |
| OFF | OFF | OFF | OFF | OFF | OFF | OFF | OFF | Off, 12 V power not connected | unknown |
| Blink | OFF | OFF | OFF | OFF | OFF | OFF | OFF | Standby, waiting for communications | unknown |
| OFF | Blink | OFF | OFF | OFF | OFF | OFF | OFF | Standby, waiting on mode input | unknown |
| Blink | Blink | OFF | OFF | OFF | OFF | OFF | OFF | Standby, waiting on engine idle | OFF |
| Blink | Blink | Blink | OFF | OFF | OFF | OFF | OFF | Standby, Techtool connected | ON |
| ON | Flash | OFF | ON | ON | ON | ON | ON | Preset 1 On, Chassis Ready Condition OK, RPM control message sent, waiting on vehicle response | Idle |
| ON | Flash | OFF | Flash | ON | ON | ON | ON | Preset 1 On, shifter not in Park | Idle |
| ON | Flash | OFF | ON | Flash | ON | ON | ON | Preset 1 On, park brake not set | Idle |
| ON | Flash | OFF | ON | ON | Flash | ON | ON | Preset 1 On, service brake not set | Idle |
| ON | Flash | OFF | ON | ON | ON | Flash | ON | Preset 1 On, vehicle speed greater than 3 MPH | Idle |
| ON | Flash | OFF | ON | ON | ON | ON | Flash | Preset 1 On, accelerator pressed | Idle |
| ON | OFF | Flash | ON | ON | ON | ON | ON | Charge mode/Preset 2 On, Chassis Ready Conditions OK, RPM control message sent, waiting on vehicle response | Idle |
| ON | OFF | Flash | Flash | ON | ON | ON | ON | Charge mode/Preset 2 On, shifter not in park | Idle |
| ON | OFF | Flash | ON | Flash | ON | ON | ON | Charge mode/Preset 2 On, park brake not set | Idle |
| ON | OFF | Flash | ON | ON | Flash | ON | ON | Charge mode/Preset 2 On, service brake pedal pressed | Idle |
| ON | OFF | Flash | ON | ON | ON | Flash | ON | Charge mode/Preset 2 On, vehicle speed greater than 3 MPH | Idle |
| ON | OFF | Flash | ON | ON | ON | ON | Flash | Charge mode/Preset 2 On, accelerator pressed | Idle |
| OFF | OFF | OFF | ON | OFF | OFF | OFF | OFF | Non-supported truck | unknown |

LED Trouble Shooting Flowchart

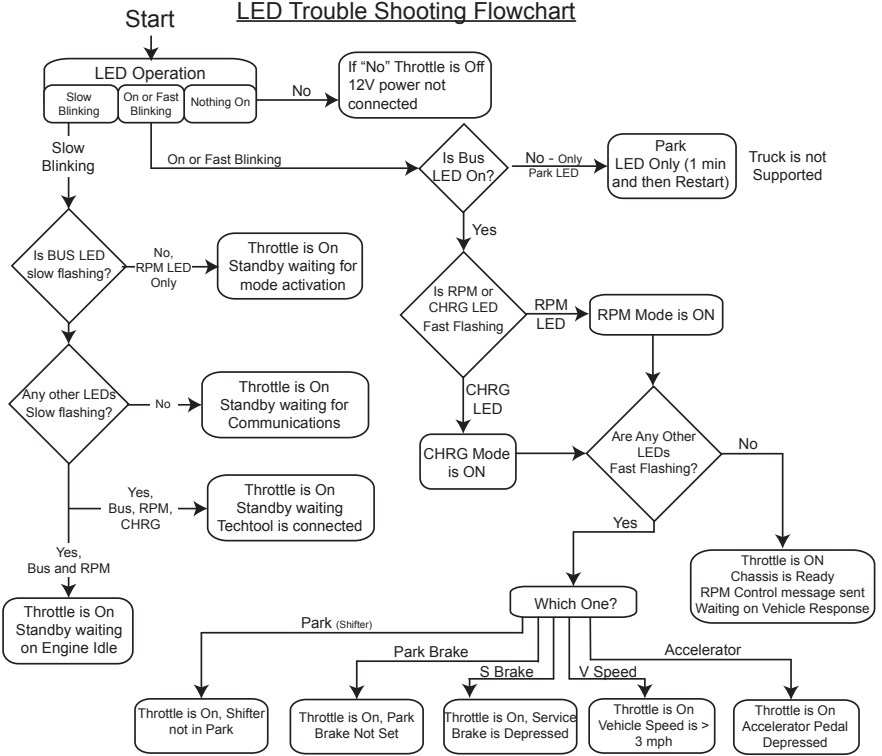

7. System Specifications

Module Inputs

Power Input: +12 volts is sourced from Pin 7 on the OBD-II connector
RPM1 Input: Ground to activate on Models DBT-LD-01 and DBT-LD-04
+12 Volts to activate on Models DBT-LD-02 and DBT-LD-03
RPM2 Input: Ground to activate on Models DBT-LD-01 and DBT-LD-04
+12 Volts to activate on Models DBT-LD-02 and DBT-LD-03
Speed Adjust Input: +12 volts to increase speed. Ground to decrease speed.
The engine speed will change at a rate of 10 RPM per second.

Module Outputs

High Idle Active Output: +12 volts @ 3 amps. Set when Chassis Ready Conditions are met, the mode input is activated, and the speed request was sent to the engine controller.
Engine RPM Ramp Rates:
Ford: 100 RPM per second
GM: 50 RPM per second

Mechanical

Dimensions: 3.165 x 1.94 x 0.798 inches
Weight: 0.046 lb
Operating Temp: -40° C to +85° C

Factory Settings

| | | | |
|----------|----------|------------------|----------|
| Preset 1 | 1500 RPM | Green Charge Max | 1500 RPM |
| Preset 2 | 900 RPM | On/Off Charge | 1500 RPM |

7. System Specifications

Module Inputs

| | |
|---------------------|---|
| Power Input: | +12 volts is sourced from Pin 7 on the OBD-II connector |
| RPM1 Input: | Ground to activate on Models DBT-LD-01 and DBT-LD-04 +12 Volts to activate on Models DBT-LD-02 and DBT-LD-03 |
| RPM2 Input: | Ground to activate on Models DBT-LD-01 and DBT-LD-04 +12 Volts to activate on Models DBT-LD-02 and DBT-LD-03 |
| Speed Adjust Input: | +12 volts to increase speed. Ground to decrease speed. The engine speed will change at a rate of 10 RPM per second. |

Module Outputs

| | |
|--------------------------|--|
| High Idle Active Output: | +12 volts @ 3 amps. Set when Chassis Ready Conditions are met, the mode input is activated, and the speed request was sent to the engine controller. |
| Engine RPM Ramp Rates: | |
| Ford: | 100 RPM per second |
| GM: | 50 RPM per second |

Mechanical

| | |
|-----------------|-----------------------------|
| Dimensions: | 3.165 x 1.94 x 0.798 inches |
| Weight: | 0.046 lb |
| Operating Temp: | -40° C to +85° C |

Factory Settings

| | | | |
|----------|----------|------------------|----------|
| Preset 1 | 1500 RPM | Green Charge Max | 1500 RPM |
| Preset 2 | 900 RPM | On/Off Charge | 1500 RPM |

8. System Diagram

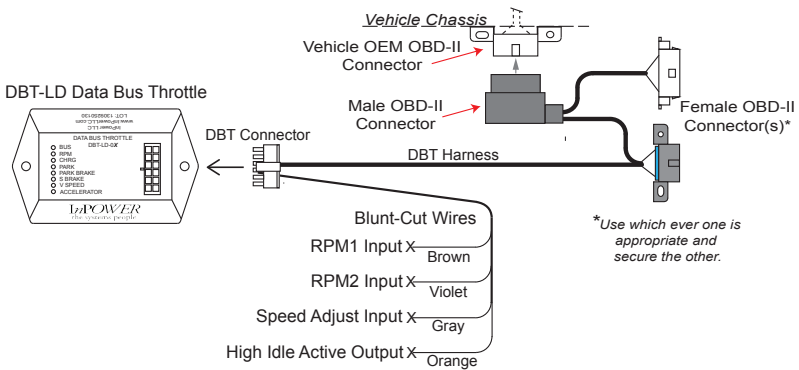

Customer Supplied Speed Mode Switches

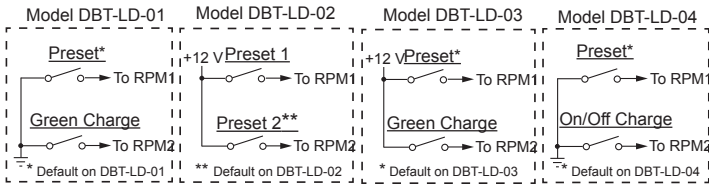

9. Mechanical Drawing

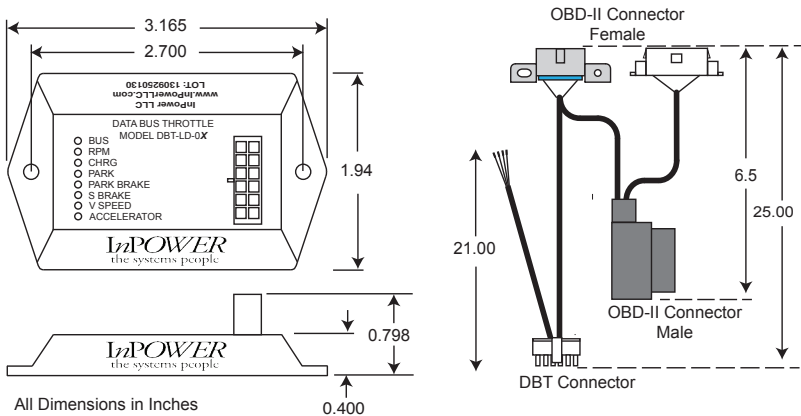

Contact Us

InPower LLC
8311 Green Meadows Drive
Lewis Center, Ohio 43035
740-548-0965
www.InPowerLLC.com